



LADDER COMPANY OPERATIONS:
PORTABLE LADDERS

CONTENTS

<u>SECTION</u>	<u>TITLE</u>	<u>PAGE</u>
	Glossary.....	i
1	Introduction.....	1
2	Sizes and Types of Portable Ladders in Use.....	1
3	Construction of Portable Aluminum Ladder.....	3
4	Advantages of Aluminum Ladders.....	4
5	Disadvantages of Aluminum Ladders.....	4
6	Storing and Securing Portable Ladders on Apparatus.....	4
7	Marking Portable Ladders.....	5
8	Placing Portable Ladders in Service - Initial Operations.....	6
9	Climbing and Operating on Portable Ladders.....	8
10	Other Uses of Portable Ladders.....	11
	10.2.1 To Bridge a Fence.....	11
	10.2.2 Deleted.....	13
	10.2.3 As a Barrier.....	13
	10.2.4 Deleted.....	13
	10.2.5 In a Tower Ladder Basket.....	13

11	Uses of Portable Ladders at Fires	14
11.2	Buildings Requiring Portable Ladders.....	14
11.2.1	Tenements and Multiple Dwellings	14
11.2.2	Brownstone Buildings.....	16
11.3	Other Uses of Portable Ladders at Fires	19
11.3.1	Forcible Entry	19
11.3.2	Ventilation	20
12	Uses of Portable Ladders - Emergencies	22
13	Safety.....	23
13.1	General.....	23
13.1.16	Electrical Hazards	24
13.2	During Operations	24
14	Maintenance of Portable Ladders.....	25

GLOSSARY

Beam	The solid or trussed main structural side member of a ladder, supporting the rungs.
Bed ladder/Bed section	The lower section of an extension ladder into which the upper section retracts.
Butt	The bottom or base end of a ladder.
Butt plates / Cleats / Spikes / Spurs / Shoes	The steel spikes mounted on the butts to provide a more secure base for the ladder on hard surfaces such as concrete. They also serve as a protection against excessive wear on the ends of ladders.
Combination ladder	A versatile ladder that can serve as a straight ladder or be converted to an "A" type ladder: i.e., Metal Duo-Safety "A" Ladder and Little Giant Ladders.
Extension ladder	A ladder with two sections that can be nested for ease of handling and extended to provide the needed height.
Fly ladder/fly section	The extendible top section of an extension ladder.
Folding ladder	A ladder designed for use in inaccessible areas where ordinary ladders will not fit: the rungs fold completely into the beams when fully closed.
Guides/channels	Light wood strips or metal channels which guide the fly ladder while it is being raised.
Gusset plate	A flat metal plate used in truss constructed ladders, which connects the rails of the beams and supports the rungs.
Halyard	A rope used to elevate the fly section of an extension ladder.
Hook ladder/roof ladder	A ladder equipped with folding hooks at the top
Ladder locks	A locking mechanism that secures an extension ladder in the desired extended position by engaging the beams of the fly ladder to the rungs of the bed ladder. Also called dogs or pawls.
Latching device	A device used on combination ladders to lock the ladder in position. Consists of hinges/pins.

Pulley	A grooved wheel attached to the bed ladder of an extension ladder, through which the halyard is drawn.
Rails	The two lengthwise members of a trussed ladder beam, which are connected by the gusset plates.
Rungs	The cross members between the beams of the ladder, used as footrests in climbing.
Safety shoe	A swivel type butt plate consisting of rubber tread and a spike. It may be used with either the rubber or the spiked end on the ground.
Solid beam ladder	A ladder with beams of solid construction (see trussed ladder).
Stops	A limiting device on extension ladders to prevent fly ladder from over-extending out of the bed ladder.
Straight ladder	A ladder with only one section.
Tip or top	The upper end of a ladder.
Trussed ladder	A ladder with beams of open construction consisting of rails and gusset plates.

1. Deleted.

2. SIZES AND TYPES OF PORTABLE LADDERS IN USE

2.1 Deleted.

2.1.1	Extension Ladders	Closed Length	Weight
	35'	20'	135 lbs.
	25'	15'	100 lbs.
	24'	14'	80 lbs.
	16'	10'	70 lbs.
2.1.2	Straight Ladders		Weight
	20'		55 lbs.
	20'(Hook)		60 lbs.
	12'(Hook)		35 lbs.
2.1.3	Deleted		
2.1.4	Special Ladders	Closed Length	Weight
	14' 'A' Frame	7'	35 lbs.
	10' 'A' Frame	6'	22 lbs.
	19' Little Giant	5'7"	40 lbs.
	15' Little Giant	4'7"	36 lbs.
	11' Little Giant	3'7"	32 lbs.
	10' Folding	11'	16 lbs.

Note: All weights, and the closed lengths of the extension ladders, are approximate, due to variation between manufacturers. Refer to Figure 1 for the various parts of a metal extension ladder.

2.2 The marine companies carry 12 foot and 20 foot portable hook ladders with wood beams. They are painted black except for the hooks and for 18 inches at the base of each beam, which are painted white. The length of the ladder and company identification are stenciled on the exterior of both beams. The hooks, unlike those on roof or hook ladders carried by land units, are fixed. These ladders do not have metal spurs at the base; there are simply the squared edges of the wood beams.

SAMPLE METAL EXTENSION LADDER

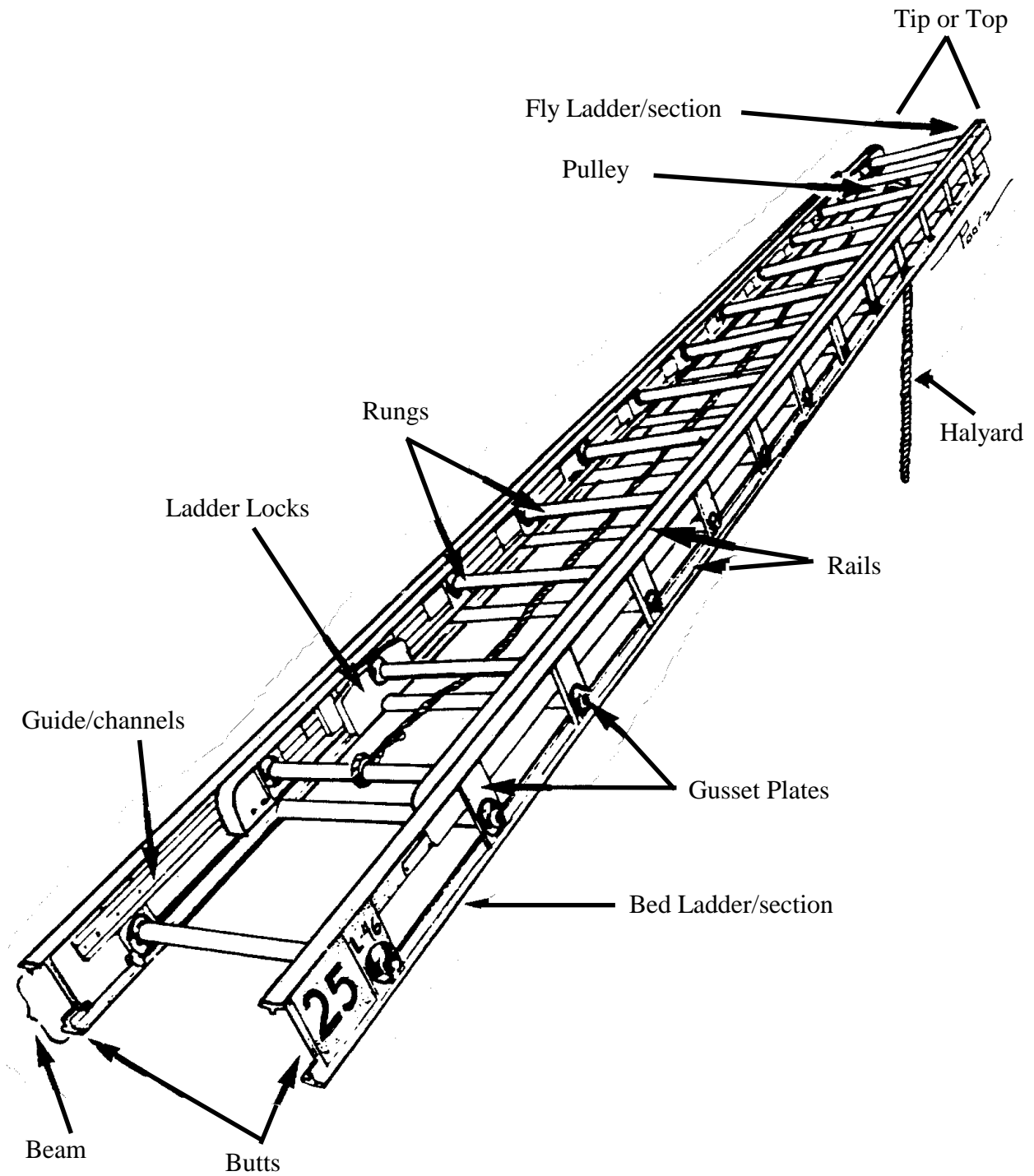

Figure 1

3. CONSTRUCTION OF PORTABLE ALUMINUM LADDERS

3.1 Aluminum ladders are divided into two basic types of construction, viz., solid beam and truss.

3.1.1 **Solid Beam Aluminum Construction** - This type of ladder has a solid side rail construction with aluminum rungs connecting with the side rails at fourteen inch intervals. The connection is generally either by a welded joint between rung and side rails, or by an expansion plug pinching the rung tightly to the side rails and internal backup plates. (Figure 2 A)

3.1.2 **Aluminum Truss Construction** - In the aluminum truss design, the top and bottom rails are connected to rung assemblies or rung blocks by rivets. The rungs are either welded or expansion plugged to the rung plate assemblies, which are supported by the top and bottom rails. (Figure 2B)

A. This construction allows greater side beam heights for greater carrying capacities without requiring massive solid beams that add to the overall weight of the ladder.

3.2 The base of the portable aluminum ladder is provided with either steel spikes or swiveling rubber safety shoes and aluminum spikes. For ladders equipped with the swiveling device, the rubber pads should be utilized when the ladder is to be raised and used on hard surfaces. (Figure 2A, 2B)

Figure 2B

Figure 2A

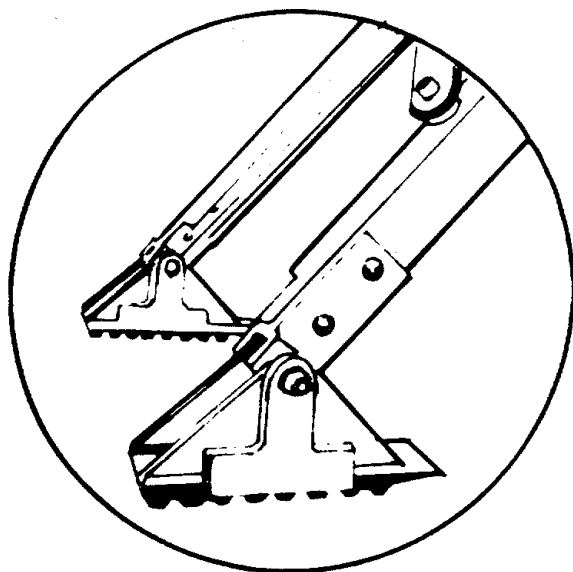

Solid Beam Construction with Swivel Safety Shoes and Aluminum Spikes

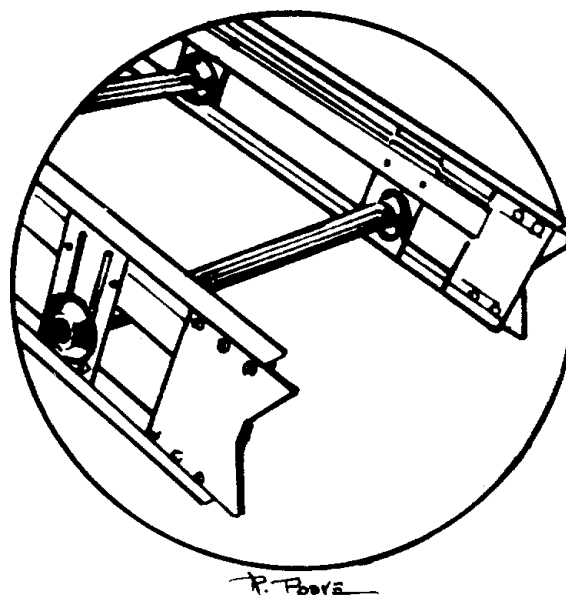

Truss Construction with Steel Spikes

4. ADVANTAGES OF ALUMINUM LADDERS

- 4.1 Aluminum ladders are generally lighter in weight and stronger than comparable wood ladders.
- 4.2 They are made of a high tensile, heat treated aluminum alloy and can sustain daily wear and tear very well. The aluminum will not weaken with age. It has a long life expectancy.
- 4.3 Aluminum ladders in general are tough. They will dent but will not chip or crack when subjected to severe impact nor will they fail suddenly because of overloads. They will bend but not break, as wood does.
- 4.4 No protective finish is required on aluminum ladders, as they will not dry out and weather with age or sunlight exposure. A slow oxidizing of the surface occurs but it can be polished off.

5. DISADVANTAGES OF ALUMINUM LADDERS.

- 5.1 Aluminum ladders readily conduct electricity. Refer to Sections 13-1.16 and 13.2.3A.
- 5.2 The ladders conduct heat very rapidly. Refer to Section 13-1.12.
- 5.3 If an aluminum ladder has been subjected to excessive heat exposure at a fire, even for a brief period, it may have lost its heat treatment. This may affect its load carrying capacity, even though the metal shows no signs of any change. A discoloration may indicate a loss of structural strength. In such cases, the Technical Services Division shall be notified.

6. STORING AND SECURING PORTABLE LADDERS ON APPARATUS

- 6.1 Ladder brackets and clamping devices on apparatus must be designed to fit the ladder being held. They should be in good condition to insure security of the ladder. They should be supported at regular intervals so that the ladders do not take a 'set' from long periods of non-usage.
 - 6.1.1 If the ladder is stored in slides or in internal racks on the apparatus, it should remove easily without force.
 - 6.1.2 Upon receipt of spare apparatus ladder brackets should be checked for their holding capabilities as they relate to the unit's ladder inventory.
 - A. If ladders cannot be held securely, the Technical Services Division shall immediately be notified by telephone. A requisition shall be forwarded and an entry made in the company journal.

- B. Provision shall be made to secure ladders as safely as possible pending repair or relocation of ladder holding devices by the Technical Services Division. These temporary fastenings shall be checked after each response.
- C. If the officer on duty feels that a particular ladder cannot be temporarily secured to the spare apparatus in a safe manner, and there is a danger of loss of the ladder during response, the ladder shall be left off the apparatus. An entry of this action shall be made in the company journal.

7. MARKING PORTABLE LADDERS

- 7.1 The numerical length of a ladder shall be marked on the side of the rails within 12 inches of the end of the ladder.
 - 7.1.1 **Straight ladders** - The ladder length shall be marked on each end of each rail.
 - 7.1.2 **Extension ladders** - The ladder length shall be marked at the butt end only of each rail of the bed ladder.
 - 7.1.3 Ladder length markings shall be visible when ladders are stored on the apparatus.
- 7.2 The unit designation shall be marked within 18 inches of each butt end as outlined in Sections 7.1.1 and 7.1.2 for numerical ladder length markings.

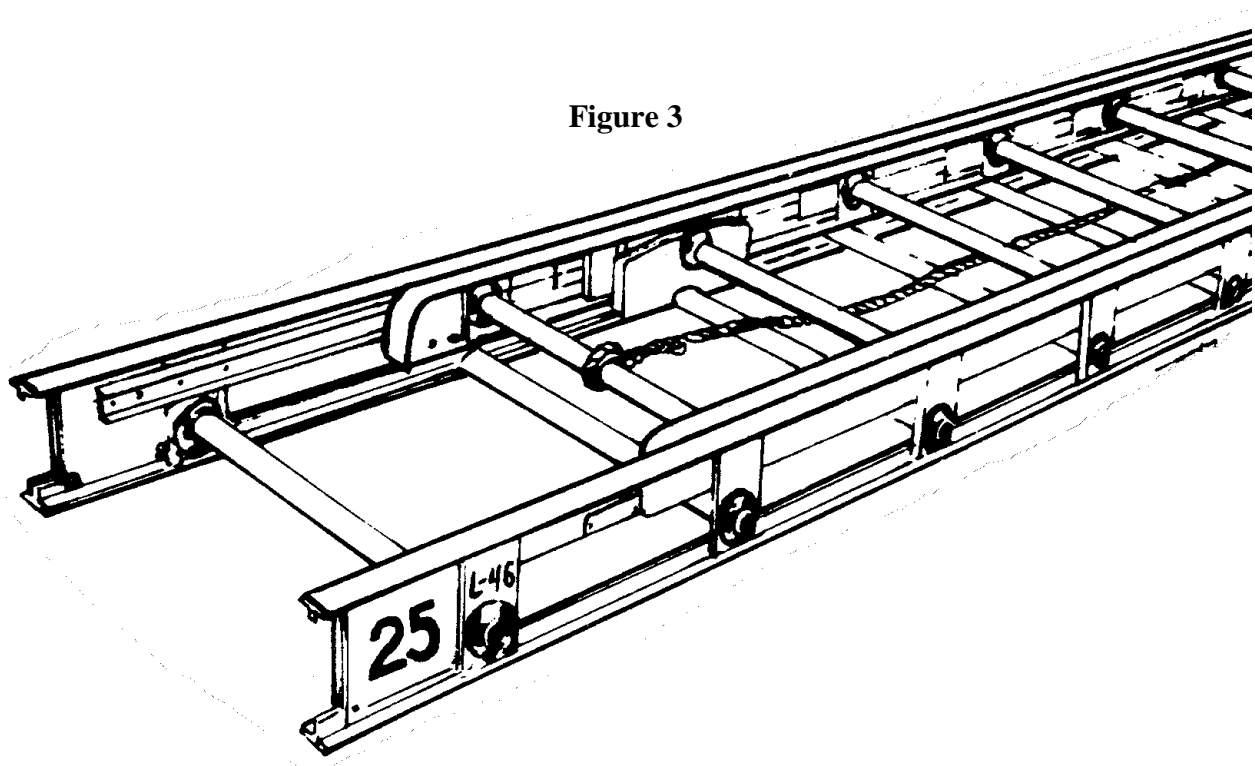

8. PLACING PORTABLE LADDERS IN SERVICE - INITIAL OPERATIONS

8.1 Avoiding Obstructions to the Removal of Portable Ladders from Ladder Company Apparatus.

8.1.1 20 foot straight and/or 35 foot extension ladders are carried in the internal slide-in racks on many ladder company apparatus. If another apparatus arriving at a fire or emergency is positioned closer than 20 feet to the rear of the ladder apparatus, the 20 foot straight or the 35 foot extension ladder cannot be removed from these racks due to insufficient clearance.

8.2 The advantage of an extension ladder is that its height can be adjusted for safe and accurate positioning. Choosing the precise ladder length is not as critical when using an extension ladder as it is when using a straight ladder which has a fixed length.

8.3 Deleted.

8.4 **Ladder Climbing Angle** - Climbing angle for a ground ladder is approximately 65-75 degrees.

8.4.1 The 65-75 degree angle allows the ladder to provide its maximum strength and best service.

8.4.2 An angle steeper than 75 degrees increases the chances of the climber falling off and sustaining injuries.

8.4.3 Ladders angled less than 65 degrees require a reduction in maximum loading. (See Section 9.4)

8.4.4 A simple formula used to obtain a 75 degree angle is to place the base of the ladder at a distance from the vertical plane equal to 1/4 the total working length of the ladder. The working length is the distance from the base of the ladder to the top of its support. (Fig. 4A, 4B)

8.5 **Ladder Placement** - Proper placement of the tip of the portable ladder provides for easier and safer mounting and dismounting of the ladder and it allows the user to maintain his balance by providing a handhold.

8.5.1 Rules for Portable Ladder Placement.

A. **Placed at a window** - Tip shall be level with window sill.

B. **Placed at a roof** - Tip shall be at least 2 feet above the roof or parapet.

C. **Placed alongside a fire escape on a building wall** - Tip shall be 1 to 3 feet above the fire escape railing.

D. **Placed against a fire escape** - Tip shall be slightly above the fire escape railing.

Figure 4A

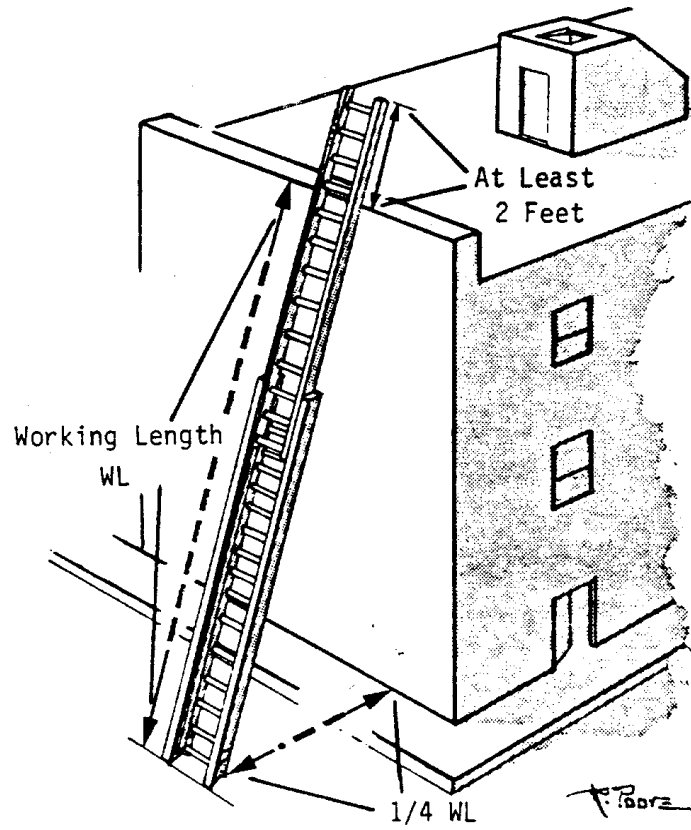
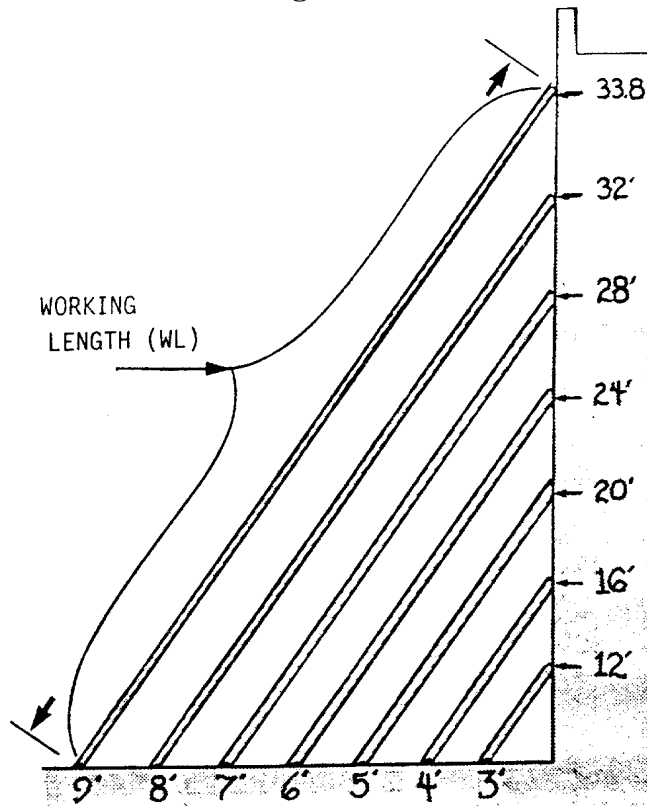

Figure 4B



8.6 Butting and Securing the Portable Ladder.

- 8.6.1 In order to prevent slippage of the butt, or movement of the top, of a raised portable ladder, it is important that it be butted by a member. In any case for fire, emergency or rescue work, a butt man shall be used to stabilize the ladder and prevent slipping.
- A. The butting member places his left foot in the center of the bottom rung of the ladder and maintains a downward pressure. His right foot is positioned behind him at a comfortable distance to maintain balance and provide resistance against ladder movement.
 - B. Both hands are placed against and grasp the ladder beams to aid in steadying the ladder.
 - C. If a member is working off one side of the ladder, the butt man moves his foot from the center of the bottom rung of the ladder to the side opposite the one from which the man is working, and places his foot next to the beam. This will prevent the bottom of the beam from shifting due to the relocated weight of the member working on the ladder.
- 8.6.2 The butt man must be aware of the force that causes the outward slippage of the butt of the ladder. This force is in direct proportion to the climbing member's weight, increases as he ascends the ladder, and is maximum at the top of the ladder. Because of this, extra care must be exercised when a member receives a victim at the top of the ladder.
- 8.6.3 The aluminum portable ladder, if it is to be left unattended, should be secured at the tip by the first member that climbs the ladder. This is to prevent the ladder from being dislodged from its position by the wind or by the impact of water from a hose line or a large caliber stream.

9. CLIMBING AND OPERATING ON PORTABLE LADDERS

- 9.1 When the portable ladder has been raised and placed in position, one member butts the ladder as outlined in Section 8.6.1. The assigned member climbs the ladder in the following manner:
- 9.1.1 Climb on the balls of the feet near the arch, left and right of the center line up and down the ladder.
 - 9.1.2 The underside of the beams are grasped with the hands.
 - 9.1.3 Climbing is done in a rhythmic, coordinated manner.
 - 9.1.4 During the climb, the eyes look up or forward.

9.1.5 If a tool is carried, it should be balanced in the carrying hand, which holds onto the side of the beam. The free hand continues to grasp the underside of the beam.

Do not carry the tool close to the body or inside the ladder over the rungs because of the danger to the butt man below should the tool be accidentally dropped

9.1.6 During freezing weather when ice forms on the ladder due to water spray, to ensure safe ascending and descending:

- A. Position the rung of the ladder under the arch of the boot, next to the heel.
- B. Position the feet on the rungs directly next to the beams with each step, to avoid slipping.
- C. The hands remain on the underside of the beams. Should a member slip while climbing, he should immediately pull himself into the ladder and regain his footing.

9.1.7 Whenever a member operates on a ladder of any kind, he must have enough hand control to ensure his safety. This is an absolute necessity when on vertical ladders, such as fire escape drop ladders and gooseneck ladders to the roof. Greater physical effort is needed when using a completely vertical ladder, because a missed step or a slip of the hand will result in a vertical drop and a serious injury. A similar mishap on a ladder which is angled into an objective could result in the member falling toward the ladder other than straight down.

9.2 Duties that require the member to work from the ladder necessitate the use of a leg lock or the life belt for safety.

9.2.1 The Leg Lock:

- A. The leg performing the locking maneuver is opposite the working side. For example, if the member wants to lean to the right and vent a window, he will lock his left leg on the ladder.
- B. To perform the leg lock, the locking leg is placed over and under the rung that is two rungs above the one on which the member is standing.
- C. The instep of the locking leg is placed on the beam of the ladder opposite the member's working side. (See Figure 5).
- D. The arch of the foot on the rung is placed against the other beam.
- E. The butt man must reposition his foot as in Section 8.6.1C.

9.2.2 Using the Life Belt:

The snap hook of the life belt hooks directly to the ladder rung.

Figure 5

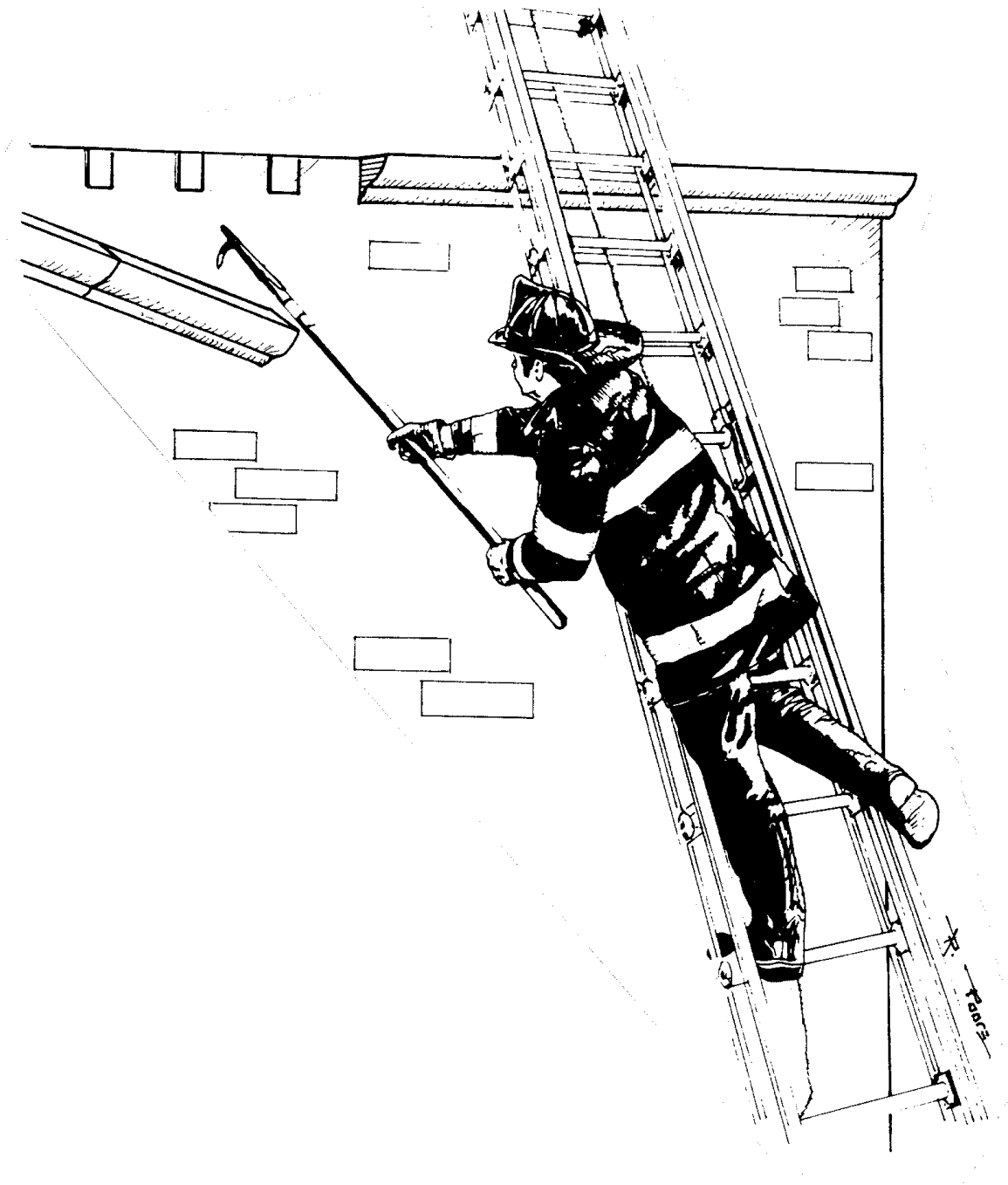

9.3 Checking Ladder Lock Assemblies:

9.3.1 The mechanical ladder lock assemblies on the extension ladders are positive action automatic spring loaded locks. If in good condition, they will work and lock in either the fly up or the fly down position. The advantage of the fly up position is that the fly ladder tends to tighten its hold on the bed ladder, when it is extended at the proper climbing angle. For this reason and for standardization, the NYFD has adopted the fly up position for the placement of extension ladders. (See Evolution 16)

- A. The first member ascending the ladder should always check the ladder lock assemblies to insure that they are completely engaged on the rung.
- B. Before dismounting from ladder, the surface to be stepped on should be probed with a tool for stability, especially when visibility is poor.

9.4 Ladder Load Capacity

9.4.1 The maximum load capacity imposed on a ladder includes the weight of the victims, members and their equipment, and any other weight such as a hose line. The ladder must be positioned correctly as outlined in Section 8.4.

9.4.2 Portable Ladder Capacities are as follows:

- A. **Collapsible ladders** - up to 300 pounds load.
- B. **Roof, straight and extension ladders** (26' or less) - up to 500 pounds load.
- C. **Extension ladders** (27' to 35') - up to 600 pounds load.

10. OTHER USES OF PORTABLE LADDERS

10.1 Portable ladders may be used in many ways and with different tools to perform a variety of functions at fires and emergencies. The most innovative uses of ladders have resulted from quick responses to unusual situations.

10.2 Uses of portable ladders at fires or emergencies may include:

10.2.1 **Used to Bridge a Fence** - At times it's necessary to gain access to a particular area surrounded by a high fence with no immediately available entry way. If the situation does not require cutting the fence, entrance may be gained by using two short portable ladders, e.g., a 16' extension ladder and a 12' hook ladder, and a short length of rope or hose strap. (Figure 6)

- A. The 16' extension ladder, nested, is placed against the fence at the proper climbing angle and butted by a member. (The nested length of the 16' extension ladder is about 10'.)
- B. One man ascends the ladder to the point where the top of the fence is at about waist level.
- C. The butt end of the 12' hook ladder is passed to the member on the 16' extension ladder. He in turn takes the ladder and places one beam on top of the fence. The hook ladder is slid out a sufficient distance, pivoted downward from the fence top, and lowered to the ground.
- D. The hook ladder is adjusted to provide a proper climbing angle.
- E. The adjacent beams of the two ladders are tied together securely where they intersect, to prevent ladder movement during use.

Note: The 16' extension ladder is used first against the fence because of its heavier weight. The 12' hook ladder is lighter and less cumbersome than the 16' ladder and may be passed more readily. Other combinations of short ladders may be used, depending on the height of the fence to be laddered and the available ladder inventory.

Figure 6



Fig. 6

10.2.2 Deleted.

10.2.3 **Used as a Barrier** - Portable ladders may be utilized as barriers to dangerous areas or conditions, to protect members or civilians from injury.

- A. A portable ladder secured across a doorway in an area where operations are in progress will indicate that entrance to that section or room of the building is restricted.
- B. Portable ladders placed on one beam, elevated to the waist level on supports and properly secured, can act as a barrier to civilian pedestrian traffic near a hazardous condition or fire operation.
- C. Short ladders may be placed over holes in floors of buildings to prevent members from falling through during operations.
- D. During any operation where ladders are used as barriers and exposed to the public, care must be exercised to prevent theft.

10.2.4 Figures 7a & 7b, revoked.

10.2.5 **Used in a Tower Ladder Basket.**- For the purpose of saving life in extreme emergency conditions, a portable ladder may be used, erected from a Tower Ladder basket to gain an extra height advantage when the maximum height and extension of the apparatus has been reached. This procedure is outlined in Fire Tactics and Procedures, Ladder Companies 6, Tower Ladder Operations, Sections 3.6.2, 3.6.3.

10.2.6 Used to support opened overhead doors and in other instances where it is necessary to supply support.

10.2.7 Used on ice covered ponds, lakes, etc. for rescues.

10.2.8 Used in bridging caved-in excavations where a person is partially buried.

11. USES OF PORTABLE LADDERS AT FIRES

11.1 Deleted.

11.2 Buildings requiring the Use of Portable Ladders - In the following examples it will be assumed that a fire of moderate to severe intensity exists somewhere within the building.

11.2.1 Tenements and Multiple Dwellings:

A Tenements without front fire escape. (Figures 8A, 8B, and 8C)

When the fire is in the cellar, 1st floor, and/or 2nd floor, raise the portable ladders adjacent to and above the fire area even if the aerial ladder will be required on the upper floors. A severe fire may render the interior stairs untenable and portable ladders will be required, even if the need is not obvious from the street.

B. Tenements and multiple dwellings with front fire escape.(Figure 9)

1. Fire escapes often become overcrowded when there is a fire anywhere within the building. Under these conditions, a portable ladder should be raised to the first balcony at a point opposite the drop ladder. If more relief for the fire escape is required, another portable ladder should be raised to the second balcony.
2. If panic conditions reign on the fire escape, attempt to keep the ladders out of reach of the people while raising and positioning them . If a panic stricken victim interferes with the ladder raising procedure, members may lose control of the ladder and it may fall and cause injury .
 - a. Panicky victims on portable ladders are a danger not only to themselves but to the rescuer as well.
 - b. If time and conditions permit, lash the ladders to the fire escape for safety.
- 2 When the overcrowding conditions have been alleviated use the portable ladders for other duties if necessary.
- 3 Be cognizant of persons in rooms not served by fire escapes.

Figure 8

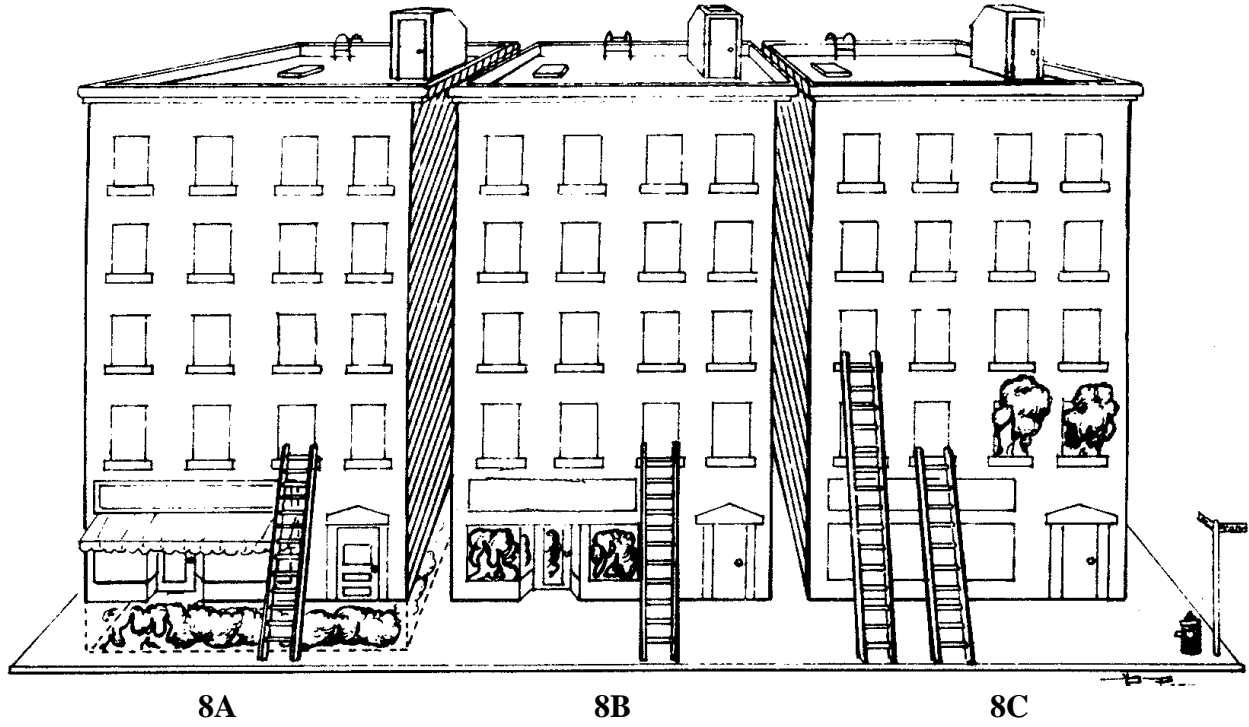
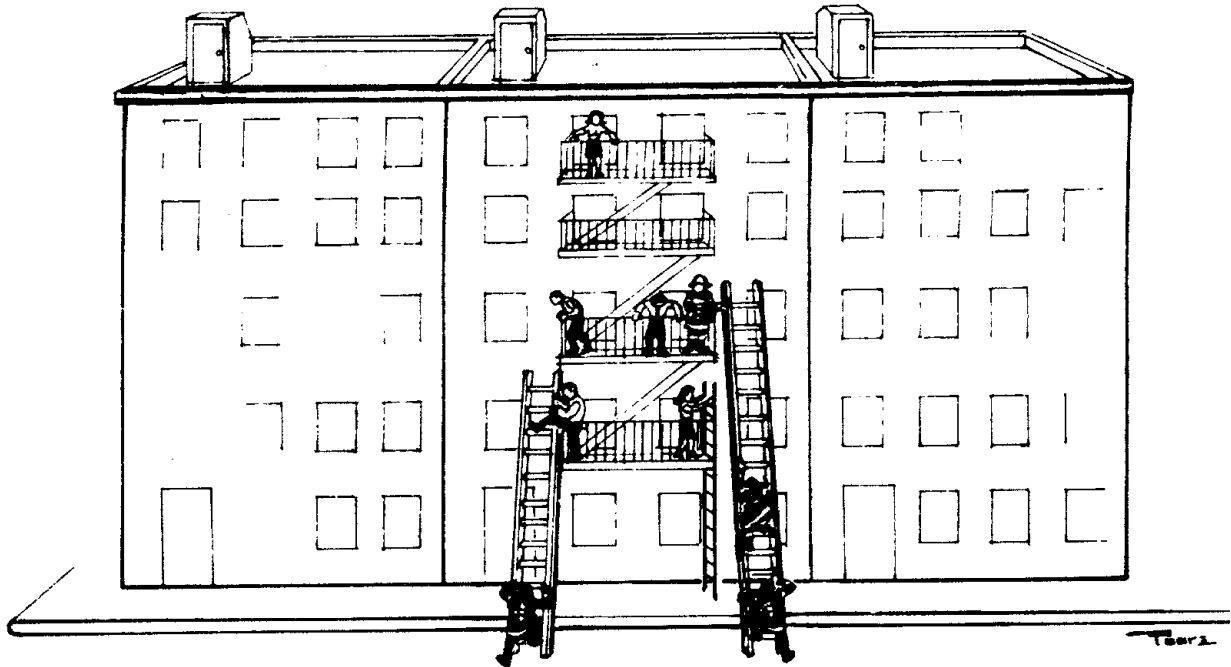

Figure 9



- C. Tenements and multiple dwellings with fire escapes on the rear of the building.
 - 1. Overcrowding on the fire escape in the rear may be relieved by members assisting occupants to the roof via the gooseneck ladder. (Figure 10)
 - 2. In the event of a fire in a building constructed with "party wall balcony fire escapes" where the fire has spread to the adjoining building, thereby eliminating it as a second means of egress, occupants may be trapped on the fire escapes.(Figure 11)
 - a. Portable ladders must, if possible, be taken through the 1st floor public hall, apartments or store to the rear yard to effect rescue.
 - b. Because of its portability the 12' hook ladder may be used to gain access to the various balcony levels by the roofman or OVM for search and rescue procedures. The ladder may be brought to the rear yard as in a) above, or brought to the roof via the Aerial or Tower Ladder and lowered to the top balcony.

11.2.2 Brownstone Buildings:

- A. Brownstone buildings are usually either 4 story (3 stories above a basement and a cellar) or 3 story (2 stories above basement and cellar)-the basement level is counted as a story. Most brownstones are similar in their construction. However, their type of occupancy varies. Although originally designed as 1 or 2 family private dwellings, they often are used as public or commercial buildings, multiple dwellings (3 or more families), and as Class 'B' rooming houses.
- B. A serious life hazard is present in brownstone buildings due to the absence of fire escapes on many of the buildings, the number of occupants (often transients) resulting from single room occupancy, and the building's combustible construction. Immediate ventilation, entry and search on the fire floor and above the fire may require the use of portable ladders.

Figure 10

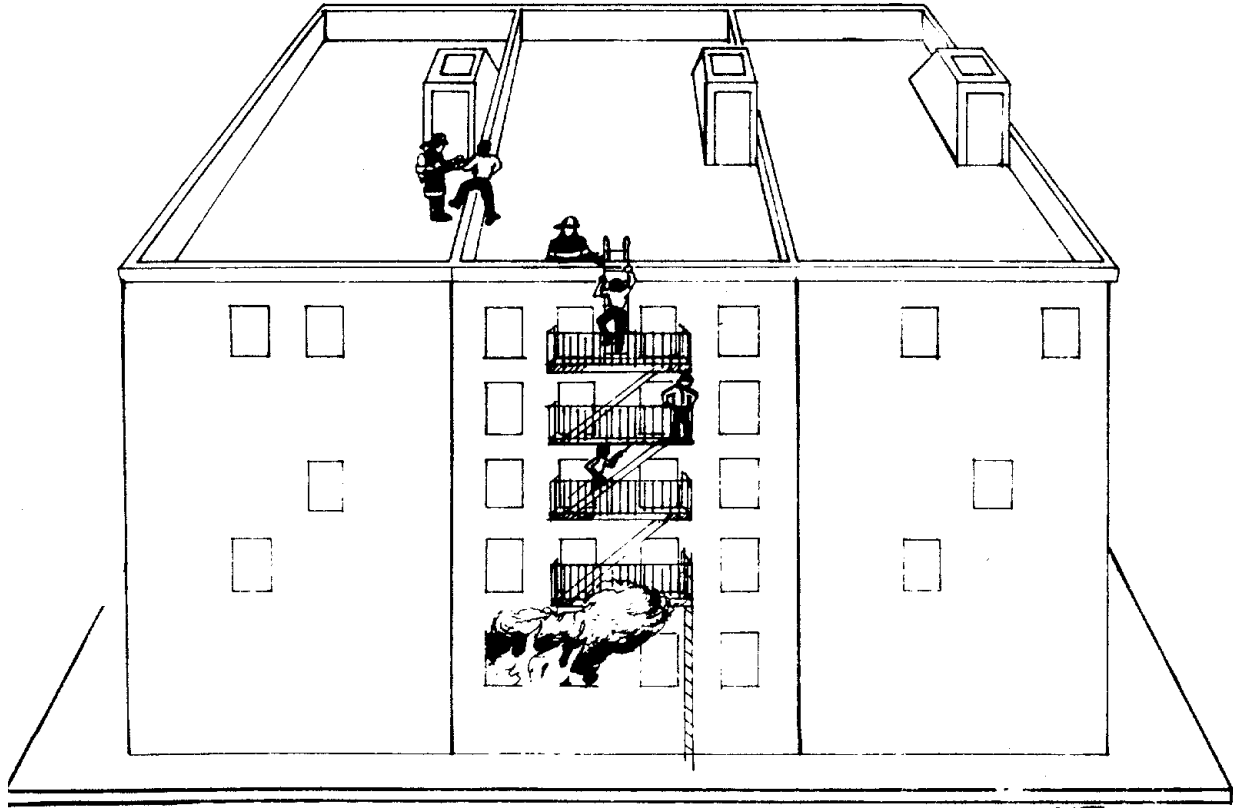
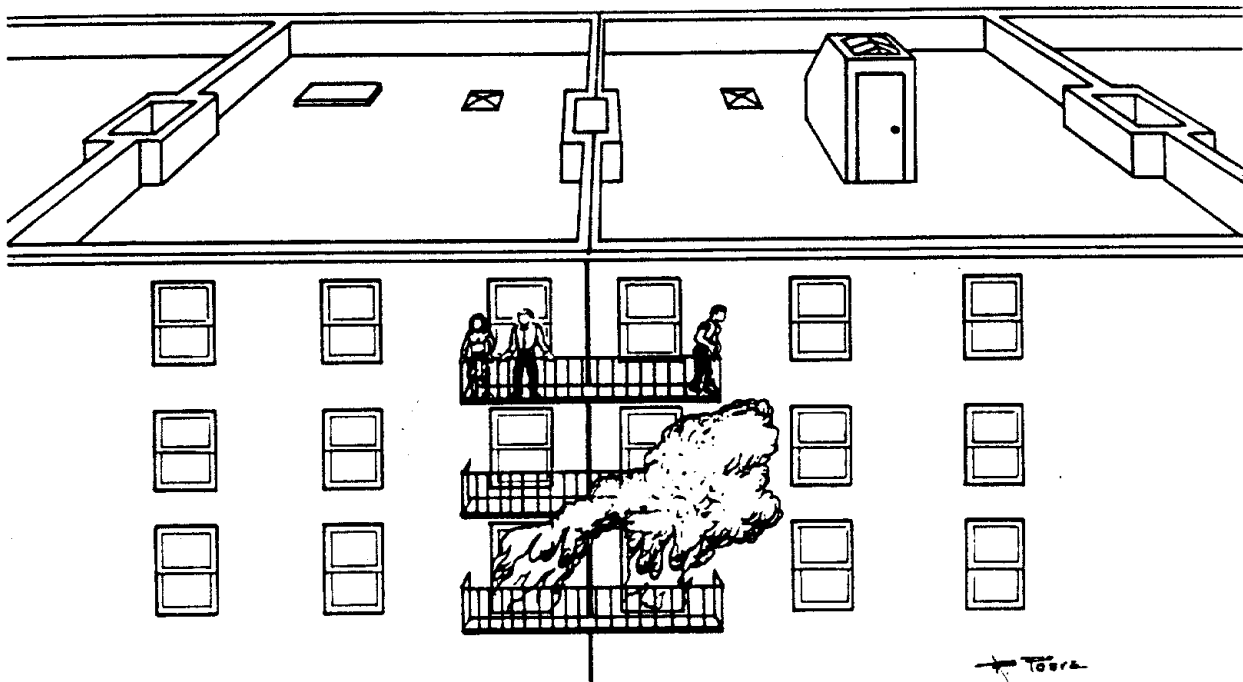
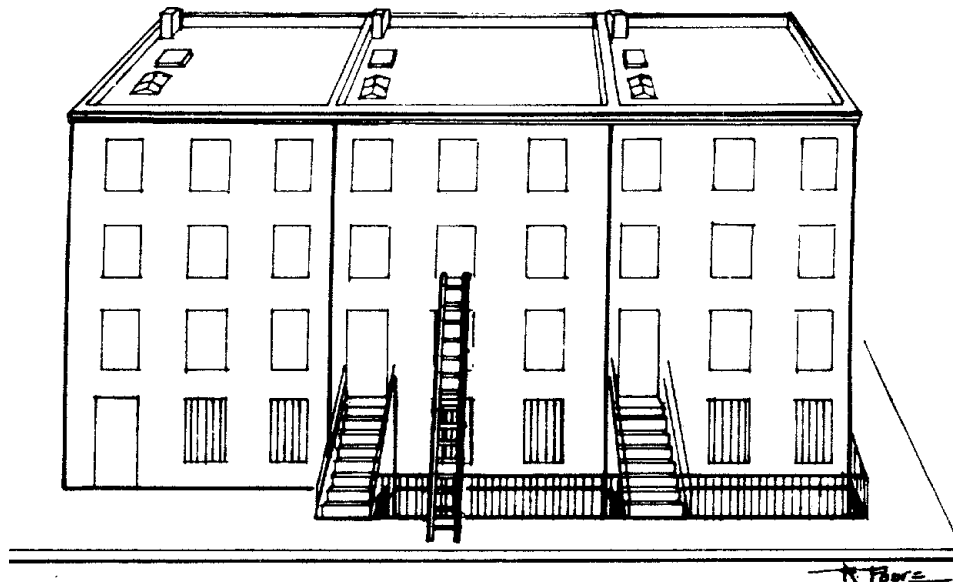

Figure 11



- C **Brownstones** - Laddering the Front of the Building:
1. Placing a portable ladder at the window of the small room over the front entrance door will be difficult because of the long, high stoop, which may interfere with firefighting operations. Consider placing the ladder at the adjoining window to gain entrance to this small room. (Figure 12)
 - a. There generally are 2 doors to the small room, one from the large adjoining bedroom and one in the hallway.
 - b. If there is no door in the small room from the large bedroom, and hallway fire conditions prevent normal entry into the small room, access may be gained by breaking through the lath and plaster partition between the two rooms.
 2. Additional laddering can be performed as outlined under 11.2.1A(1).
 3. Some brownstones have small elevated or depressed courts in the front of the building adjacent to the stoop. They generally have a small wall of iron railing around them. These present additional obstacles to overcome when maneuvering and placing portable ladders.

Figure 12



- D. **Brownstones** - Laddering the Rear of the Building:
1. The rear of the brownstone presents a severe life hazard if there is no fire escape. Portable ladders transported to the rear of the building and properly positioned are safer than a life saving rope rescue. They require less manpower and effort.
 - a. Due to operations in the fire building, to barred windows at the basement level, and to floor layout, movement of portable ladders to the rear may be difficult and time consuming,-
 - b. In most cases, taking the ladder through the second floor (parlor floor) of an adjoining brownstone, passing it out the rear window to another member in the yard below, is faster than using the fire building.

In a row frame, transporting a ladder through the interior of the building to the rear is generally less complicated because there are front and rear doors or window entries at ground level.

Note: It is important to take the ladder through with the butt facing rear of building.
 - c. Fences constructed between the properties in the rear yard may be an obstacle for rapid ladder placement.
 2. Most often, all floors in the rear of a brownstone can be reached with portable extension ladders. It is recommended that extension ladders be used in lieu of straight ladders because:
 - a. They are easier to transport because of the shorter nested length.
 - b. The ladder height can be adjusted.
 - c. One ladder may serve several floors.
 - d. Generally, floor and ladder working length are:
 - 1) 4th floor - 35' extension ladder.
 - 2) 3rd floor - 25' or 35' extension ladder.
 - 3) 2nd floor - 16' or 25' extension ladder, or 10' - 14' "A" Frame ladder.

11.3 Other Uses of Portable Ladders at Fires:

11.3.1 **Forcible Entry** - Straight ladders have been successfully used to force entry into stores and other occupancies having wood frame inward opening doors. This method will provide a margin of safety where conventional methods of forcible entry would place members in a hazardous position, e.g., when working in return show window area of plate glass panels, heat or flame prevents close approach, or where the possibility of back draft exists.

- A. Deleted.

- B. **Ventilating Lexan Windows** - Some occupancies have used Lexan panels instead of conventional glass in their windows. At times, the Lexan panel is protected by a wire screen on the exterior. These windows may be forced with a portable ladder if the window is at ground level.
1. Remove the exterior screen.
 2. Place the butt of the ladder on the Lexan window in the corner adjacent to the window frame.
 3. Three or four members apply a gradual leaning pressure against the window until it is forced inward.
 4. If a section of window snaps off, continue forcing around the window perimeter until a sufficient opening has been made.

11.3.2 Ventilation of windows on upper floors may be accomplished by the use of portable ladders with or without a member operating from the ladder.

A. Member on the Ladder:

1. The ladder is placed upwind from the window to be ventilated. The placement should provide a margin of safety to the member if the fire extends out of the window.
2. The tip of the ladder, if possible, should be level with, or higher than the top of the window.
3. The member's eye shield shall be in the down position.
4. Deleted.
5. When the member is positioned on the ladder and prepares to use a tool to ventilate the window (a 6 foot hook is preferable), he should extend his arms upward and slant the tool downward and strike the glass. This will prevent the window glass from sliding down the tool handle and causing injury to the member.
6. Placing the ladder upwind from the window will allow the falling glass, to some degree, to be blown away from the member butting the ladder below.

B. Portable ladder with only one member:

1. The member using a portable ladder to ventilate a window must wear full firefighting clothing, eye shield down, and boots pulled up. This will help prevent injury if he is struck by falling glass.
2. The ladder should be positioned so that it will break the desired window glass area when dropped against the window.

3. When the ladder strikes the glass, there should be no contact between the member and the ladder. The reason for this is that there is a great probability that the window glass will slide down the ladder beams. By the member maintaining a 'no contact' position, he reduces the chances of personal injury. Care should also be taken to insure that no other personnel are in the 'danger area'.
 4. As soon as the glass sections have fallen or are clear of the ladder, the member must stabilize the ladder to prevent its falling to the ground.
- 11.3.3 Hook ladders, in addition to their use as conventional straight ladders, may be used on sloping roofs, to gain access to piers or bulkheads, or any other application where a hanging ladder may be required. To prevent slipping on peaked roofs, set hooks into roof by pulling down on ladder.
 - 11.3.4 Portable ladders may be placed over weakened, damaged or burnt-out stairs in order to safely gain access to upper stories of a building.
 - 11.3.5 Portable ladders may be used to gain access to a higher or lower roof level from an adjoining roof
 - 11.3.6 When portable ladders are placed over holes in a floor or roof or over a shaft opening, they aid in preventing members from falling into these unprotected openings. Other objects placed on top of the ladder will identify the hazard and can provide additional coverage over the opening.
 - 11.3.7 Portable ladders used in bridging operations can span courts, alleys, shafts and similar openings between floors and roofs. Extension ladders must be used only in the nested position when bridging.
 - 11.3.8 Short ladders are used to support a bent cellar pipe during its operation, from exterior cellar stair or below grade openings. The ladders can also be placed across trench cuts, holes in a floor, or other openings to facilitate distributor use in cocklofts, cellars or wherever they are required.
 - 11.3.9 In order to prevent electrically operated overhead doors from closing when power in the fire building is shut down or affected by fire, a short ladder may be used to chock the door in the open position.
 - 11.3.10 All Unit Circular 200 states that, during winter months when snow conditions prevent or restrict approach of the apparatus close to the fire area, in transporting heavy equipment and rolled or folded hose, the ladder as a sleigh should be considered. The ladder should be covered lengthwise with a tarpaulin, wide boards or other materials to help support the hose or other equipment and prevent it failing through the ladder, dragging in the snow, or being lost.

- 11.3.11 When a ladder has been positioned and used by a member to gain entry to a fire building, there is the possibility that he will also need it as a means of retreat. He expects the ladder to be there. Therefore, do not move or reposition a ladder used in this manner except if it is necessary to use the ladder for rescue.

12. USES OF PORTABLE LADDERS - EMERGENCIES

- 12.1.2 Deleted.
- 12.1.3 Deleted.
- 12.1.4 Deleted.
- 12.2 In order to perform an emergency search, portable ladders may be used as a brace where there is partial collapse of a floor area. The ladders may be used singly or in groups depending upon the extent of the collapse and the amount of stress to which the ladders will be subject. To insure that the searching members' lives are not jeopardized, the collapse condition must not be underestimated. Therefore extreme care and judgment must be exercised.
- 12.3 Portable ladders may be used in an emergency to shore excavations, or reinforce weakened walls. The proper placement of ladders and planks can prevent refilling of areas that are being dug out.
- 12.4 Deleted.
- 12.5 During winter months, portable ladders may be used for the rescue of victims that have fallen through ice that has formed on bodies of water. Laid flat on the ice, the ladder distributes the weight of the rescuer and/or the victims over a larger area of ice. It thereby reduces the total weight concentrated at any one point.
- 12.5.1 If it is necessary for a member to proceed out on the ladder to attempt rescue, he shall be secured with a life safety rope as a safety precaution.
- 12.6 Elevator emergencies may at times necessitate the use of a portable ladder.
- 12.6.1 The ladder may be used to remove occupants from a stalled elevator car stuck between the floors of a building. The occupants are first relocated to the roof of the car via a ladder and then to a landing or a breached wall by a portable ladder.
- 12.6.2 Victims sometimes fall through a shaft opening and into an elevator pit or onto the top of an elevator car. Portable ladders may be required to gain access to such victims.
- 12.6.3 See Training Bulletin Elevator Operations for details.

13. SAFETY

13.1 General:

- 13.1.1 Deleted.
- 13.1.2 Deleted.
- 13.1.3 Extension ladders in general are not made to be taken apart and used as single section ladders. The upper sections normally are not furnished with any type of safety foot. Therefore they are prone to slip when used as a single ladder.
- 13.1.4 Extension ladders should never be used upside down, that is, with the round ends down, since this will cause the ladder to slip on the ground. Also, the lock assemblies will not be able to function correctly.
- 13.1.5 When an extension ladder is raised, the halyard shall be tied off to the lower section of the ladder as a safety measure and prevent the ladder locks from accidentally unlocking by a pull on the rope.
- 13.1.6 Make sure the ladder is set on a firm foundation. Before climbing, take care to see that it does not wobble.
- 13.1.7 Ladders should never be placed against window panes, window sashes, or loose boxes, barrels, or other surfaces that may break or collapse.
- 13.1.8 Always face the ladder when ascending or descending.
- 13.1.9 Do not climb higher than the third rung from the top on either straight or extension ladders.
- 13.1.10 Resist the temptation to overreach. It is better to get down and move the ladder.
- 13.1.11 When using a ladder for access to high places, it shall be securely lashed or otherwise fastened at the top to prevent slippage.
- 13.1.12 Deleted.
- 13.1.13 Never maintain a defective ladder in service. When a defect in a ladder is found during an in-quarters inspection or damaged at a fire, remove the ladder from service and notify the Technical Services Division for their recommendation as to collection, repair or replacement.

13.1.14 Hooks of roof ladders in general are used to secure the ladder over the peak of a house or to hang it from a wall edge or window opening. Be sure the bolts are secure on the roof hooks and that the hooks have not been accidentally bent open.

13.1.15 Many pumper extension ladders, when in position in the ladder holding brackets on the side of the apparatus, protrude enough to create a potentially hazardous condition. Care should be exercised when mounting the back step of the pumper.

13.1.16 Electrical Hazards:

A. Both metal and, under certain conditions, wooden portable ladders can conduct electricity. The fact that a metal ladder will conduct electricity is obvious. However, wet wooden ladders or the metal component parts such as tie rods, wire cables, ladder lock assemblies and the like, when in contact with electrical wires or equipment can do likewise.

B. Whenever a portable ladder is to be raised and transported in a vertical position, special care must be exercised near overhead electrical wires.

C. If a member becomes part of an electrical circuit, either by raising a ladder that touches a live wire or by the member touching a live wire while on a ladder, he can receive an electrical shock and be seriously or fatally injured.

D. Depending upon the voltage in overhead wires, the proximity of a metal ladder to them, and the quality of the grounds (ladder and electrical circuit), it may not be necessary to actually touch the wires to suffer an electrical shock. Electrical current can arc and jump the distance between the ladder and the wires and cause death to an unsuspecting member.

13.2 During Operations:

13.2.1 After a portable extension ladder has been raised and placed into a position against a building, do not lower the ladder by pulling the butt end further away from the building.

A. Doing it will reduce the load capacity as the angle becomes more shallow.

B. There is a great possibility that it will unlock the lock assemblies in the upper section.

C. Always lower the fly ladder below the desired level and reraise it in order to insure a safe 65 - 75 degree climbing angle and also the proper locking action of the lock assemblies.

- 13.2.2 When ventilating the upper windows of a building with a portable ladder, watch for glass shards sliding down the beam. (Section 11.3.10B)
- 13.2.3 When placing a metal portable ladder against a building constructed with an aluminum siding exterior, the member should release the ladder before contact is made with the building.
- A There have been occasions when the aluminum siding was energized due to a faulty electrical service connection or a faulty ground, or due to the service being damaged by fire conditions. If a member places an aluminum ladder on such a building, he could make himself part of an electrical circuit and receive an electric shock.
- 13.2.4 Position metal ladders away from electrical service wires entering buildings from utility poles. Injury to a member can be caused by the member brushing against wires having an outer insulation covering that is in a deteriorated condition.
- 13.2.5 When operations are to be conducted at electrical generating stations or substations, under NO circumstances shall metal ladders or tools be brought inside the gates.
- A. Never place a ladder of any type, wood or metal, against what appears to be metal superstructure. It may turn out to be some form of electrical conductor.

14. MAINTENANCE OF PORTABLE ALUMINUM LADDERS

- 14.1 Aluminum ladders require considerably less maintenance than wood ladders and with a few simple precautions should provide long service.
- 14.2 General Maintenance:
- 14.2.1 Aluminum ladders shall be maintained free of dirt and grime. They shall be washed when necessary with warm soapy water and rinsed thoroughly.
- 14.2.2 Nicks or burrs that are found on the ladder shall be removed with a fine file in order to prevent injury to member's hand during ladder handling.

14.2.3 A visual inspection of portable ladders shall be made weekly, and also after use, to determine their condition and serviceability. Examples of ladder defects are as follows:

- A. Cracked welds.
- B. Loose rungs.
- C. Bent rungs or beams.
- D. Missing or loose rivets, nuts, or bolts.
- E. Discoloration signaling excessive exposure to heat.
- F. Broken mechanical lock assemblies on extension ladders.

14.2.4 If aluminum ladders are stored in a horizontal position they must be supported at a sufficient number of points to prevent sagging and permanent set.

14.3 Extension Ladders:

14.3.1 Ladder slides and channels.

- A. Materials used to allow the ladder sections to slide easily on each other are candle wax, paraffin and grease.
- B. Grease is normally used only for internally guided aluminum truss ladders. The grease shall be cleaned from the guiding grooves, and they shall be recoated each year, or when the grease has dried out and is no longer an effective aid to sliding.
- C. On all ladders, plain candle wax or paraffin shall be applied every three months to all contacting surfaces of multiple section ladders to insure smooth operation. Apply the candle wax or paraffin where there is contact between rungs, guides or side rails.
 - 1. Any wax that is thinner than candle wax or paraffin either spreads too thinly or rubs off almost immediately. The net result is no lubrication and the sections do not slide easily.
 - 2. If, after the application of candle wax or paraffin, the ladder sections do not move smoothly, or if they bind during use, check the ladder for damage and/or alignment problems.

14.3.2 Pulleys:

- A. Pulleys are found on all extension ladders. These pulleys usually have a ballbearing center that requires 1 to 2 drops of oil once a year.

14.3.3 Halyards:

- A. The halyards on extension ladders are generally made of manila rope. When the rope becomes frayed or twisted from usage, it should be replaced.
- 1. Manila rope is used for its overall characteristics of being a soft and strong material without excessive stretch or shrinkage.

14.3.4 Mechanical Lock Assemblies:

- A. The mechanical lock assemblies are spring loaded devices. These springs have, at times, broken or rusted off thereby placing the ladder out of service. The assemblies shall be given careful scrutiny during inspections and kept clean and well oiled.

14.4 Hook Ladders:

- 14.4.1 The hooks of the hook ladders are spring loaded and are covered assemblies to insure operation even under freezing conditions. These assemblies, like the mechanical lock assemblies in Section 14.3.4A, must be carefully inspected, kept clean and well oiled to insure proper functioning.

BY ORDER OF THE FIRE COMMISSIONER AND THE CHIEF OF DEPARTMENT